

## Features

- High resolution colour touchscreen display.
- Simple step-by-step tare and calibration routines.
- Dead Range and Automatic Zero Adjustment.
- Comprehensive Production and Management Reports.
- Automatic Angle Compensation.
- Configurable RS232/485 Serial Interface and USB port.
- Analogue Output and Network Connectivity options including: Ethernet, EtherNet/IP, Profibus DP and PROFINET.

## Description

The GW1436 *smart* Belt Weigher Indicator connects to a belt weigher mechanism in order to continually calculate the rate of flow of material over the belt scale and the total quantity of material transferred.

A wide variety of belt scale designs containing up to four load cells are supported, along with a range of speed sensor devices e.g. proximity switch with toothed wheel. Optionally, in applications where belt speed variations are insignificant, the indicator may operate from an internal speed simulator.

Precision electronics combined with an easy to read colour touchscreen display and comprehensive storage and communication options provide a state of the art solution for belt weigher installations.



## Intuitive User Interface

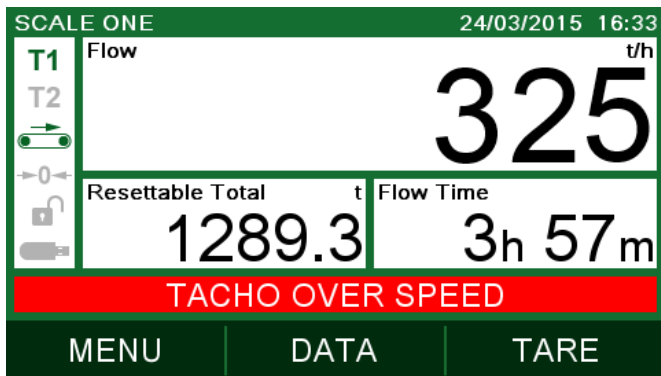

The colour touchscreen provides the operator with a high visibility display of the process data and status along with intuitive icon driven navigation.

The tiles on the main operating screen can be set to display the process data required by the user, and illuminated icons indicate device status conditions such as belt running, trip levels etc.

Alarm conditions are displayed in red to attract the attention of the operator.

## Tare, Dead Range and Auto Zero Adjustment

A step-by-step tare routine is available to the operator directly from the main operating screen.

A control parameter determines the minimum flow rate below which the indicator ceases to totalise to ensure that the production totals remain unaffected when the belt is running empty.

Whenever the unit is running within the dead range the internal zero is automatically adjusted to eliminate the effects of material build up on the belt.

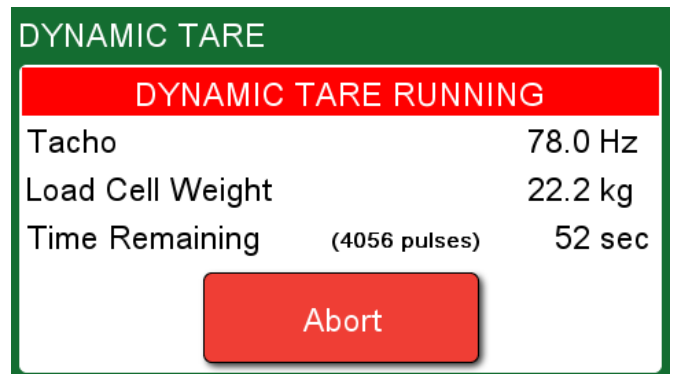

## Simple Calibration Routines

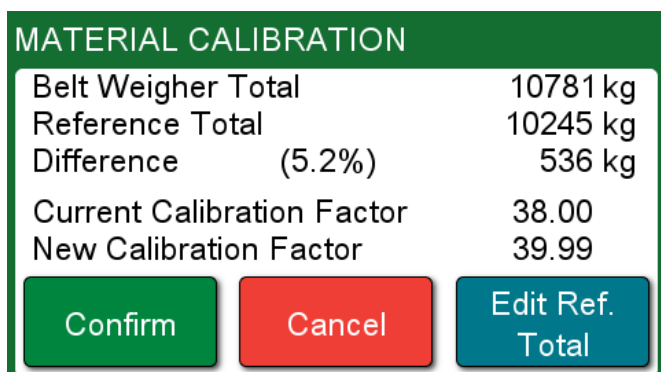

An initial setup and calibration can be established by entering the appropriate belt scale data.

A choice of material, test weight or theoretical calibration routines are supported with on-screen step-by-step instructions.

Operator confirmation of calculated calibration adjustments is required before any changes are committed and all calibration events are recorded within the event log.

## System Interface

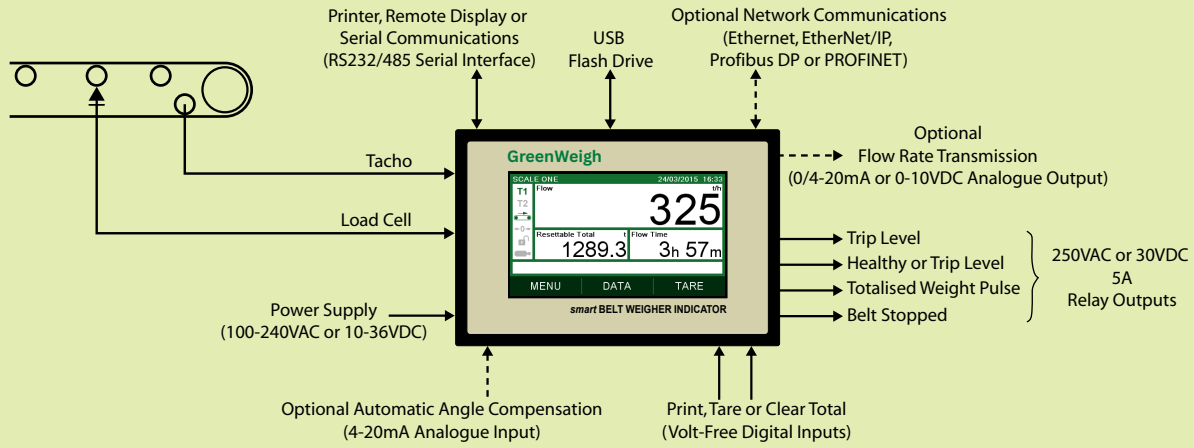

## Diagnostic Data

A comprehensive range of diagnostic data is available to provide complete system visibility.

Along with this, a historical event log provides full traceability of operating events such as: system errors, parameter changes, scale calibration and production data reset.

These features dramatically improve the ability to offer remote technical support.

EVENT DETAIL	
Time & Date	24/03/15 17:12:40
Event Type	Calibration End
Calibration Method	Material
Accepted	Yes
Belt Weigher Total	10781
Reference Total	10245
Calculated CF	39.99

## Production and Management Reports

PRODUCTION LOG	
Started	05/06/15 07:01:23
Ended	05/06/15 11:03:47
Total	902.7t
Flow Time	2h 46m
Belt Run Time	3h 10m

The production totals and times can be stored internally, and or to USB flash drive, to provide visibility of plant productivity and shift performance.

These reports can be viewed on-screen and are also stored in a standard format allowing them to be easily imported in to office management systems.

A periodic data logging feature is provided to allow continuous storage of process data to USB flash drive. The subsequent analysis of this data provides in depth detail regarding plant operating periods, productivity rates and downtime.

## Printed Batch Reports

The GW1436 is equipped with a configurable serial interface which may be used to drive a printer to produce time and date stamped printed batch reports. A duplicate copy of these reports can also be stored internally, and or to USB flash drive, for complete security and traceability.

## Automatic Angle Compensation

For applications where the conveyor angle will change during production the GW1436 is able to interface to an inclinometer device in order to determine the conveyor angle and compensate accordingly. This eliminates the need for recalibration following a change in the conveyor angle.

## Technical Data

### Power Supply:

Supply : 100 - 240V AC 50/60Hz  
or 10 - 36V DC.  
Internal mains filter fitted.  
Power : AC - 21VA max. DC - 15W max.  
Fuse : 1A anti-surge internal fuse.

### Touchscreen Display:

4.3" 16 million colour TFT display with resistive touchscreen.

### Load Cell Input:

Excitation : 10V DC @ 125mA max,  
1 to 4 x 350 ohm load cells may  
be connected in parallel.  
Range : 0-20mV min, 0-2.5V max.  
Filter : Adjustable 0.2 to 20Hz.  
Accuracy : Up to 65,000 internal divisions  
with negligible drift due to internal  
self calibration.

### Tacho Input:

Supply : 12V DC @ 120mA, short circuit  
protected.  
Type : 3 wire NPN, or volt free contact  
Shaft Encoder - open collector  
or push-pull.  
Range : 0 - 500Hz.

### Digital Inputs:

2 x volt free contact.

### Relay Outputs:

4 x volt free relay contacts.  
Voltage : 250V AC or 30V DC  
Current : 5A

### Communication Ports:

1 x Selectable RS232 or RS422/485.  
1 x USB 2.0.

### Optional Communication Port:

Ethernet, EtherNet/IP, Profibus DP or PROFINET.

### Optional Analogue Output:

Selectable 0-20mA, 4-20mA or 0-10V.

### Optional Analogue Input:

4-20mA.

### Enclosure:

Panel mounting DIN case.  
144mm wide x 96mm high x 154mm deep.  
Panel cut-out 138mm wide x 92mm high.

### Environment:

Operating : 0 to 50°C  
20-80% RH non-condensing.  
Storage : -40 to 80°C

## Communications

The GW1436 is equipped with a configurable RS232/485 serial interface which may be set to provide communications to a host system using one of the supported communication protocols.

- Modbus ASCII
- SABUS (ASCII)
- Modbus RTU

In addition to this it can be fitted with one of the following network communication interfaces to provide connectivity to a range of host systems.

- Ethernet
- Profibus DP
- Modbus TCP
- PROFINET
- EtherNet/IP

This extensive range of communication options ensures compatibility with a wide range of host systems, such as PLC control systems or PC systems via locally wired or remote cellular networks.

## USB Port

The inclusion of a USB port as standard eliminates data storage limitations and greatly simplifies the transfer of data. A USB flash drive can be used either for continuous storage of production and diagnostic data or periodic transfer of internally stored data to external systems.

A backup and restore facility, using a USB flash drive, allows a complete transfer of data from one unit to another to simplify setup and reduce downtime during servicing operations.

## Model Reference Structure

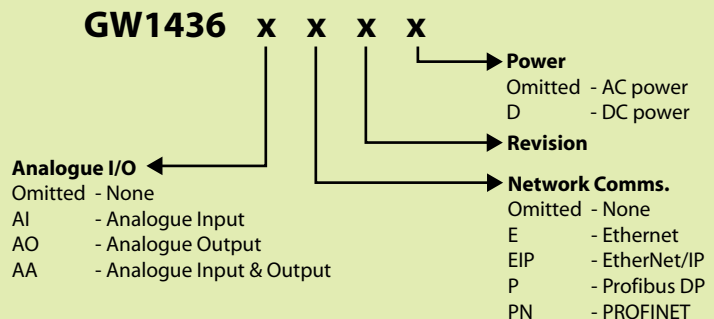

## GreenWeigh Ltd

Hollowgate Farm,  
Hollowgate,  
Froggatt,  
Derbyshire,  
S32 3ZN

Email: [rod@greenweighltd.com](mailto:rod@greenweighltd.com)

Tel: +44 (0) 7789 057 131